

Pedestrian Access Control Presentation:

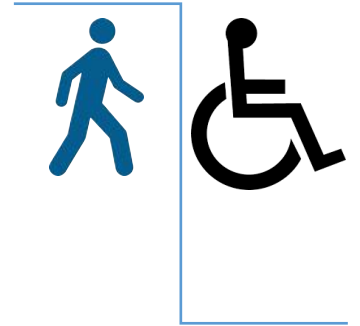

Indian Manufacturer of all types of Turnstiles

For any details please contact:

Rajesh A Bhavsar, Director

Email: [rab@vitaran.in](mailto:rab@vitaran.in), Cell: +91-94236 85581

## Why Physical access control is required ?

For Secured entry control applications , guarding properties and to protect a nuclear power station, an airport, defense base, factories, perimeter etc

It offers controlled and secure access to areas defined by the management/Security Manager.

If you need an effective security solution, turnstiles are an essential addition to your access and control plan.

For optimizing the flow of people - especially at strongly visited sites.

Turnstile gate is ideal for crowd management – providing your location with safety, convenience and efficiency. Factory turnstiles are ideal for securing the premises and integrating with the company's time and attendance system.

Physical access control system is the heart of information & perimeter security

Pedestrian physical access control solutions are designed for offering barrier of different height and grant access to only those have the appropriate permissions

They can be used for access control at entrances to factories , office, administrative complex, industrial installations, banks, airport and many places.



## Why ROBSTUR Automation ??

Robstur Automation is an Indian manufacturer of full range of entrance control products

Robstur has the product to meet all your physical access control requirement & Needs.

All Robstur turnstiles gates are easy to install, operate and maintain and can be easily integrated to advanced control systems.

Driven by passion to the entrance control solution promoters of Robstur promoters has combined experience of 40+ years of physical and logical access control.



## Robstur Automation : Product range



Refine your selection by choosing from the following secured entry control products:

- Electro-Mechanical Tripod Turnstile
  - SLIM Series
  - Neat Series
  - Classic Series
- Electro-Mechanical Tripod with automatic drop arm feature
- Motorized Drop arm Tripod with auto reset
- Motorized P type swing gate for handicapped lane
- Manual Push type Swing gate for handicapped lane
- Full Height Turnstiles
  - Single & double lane
  - Powder coated OR stainless steel frame structure & top
- Retractable Flap Barrier
  - Standard & Handicapped lane

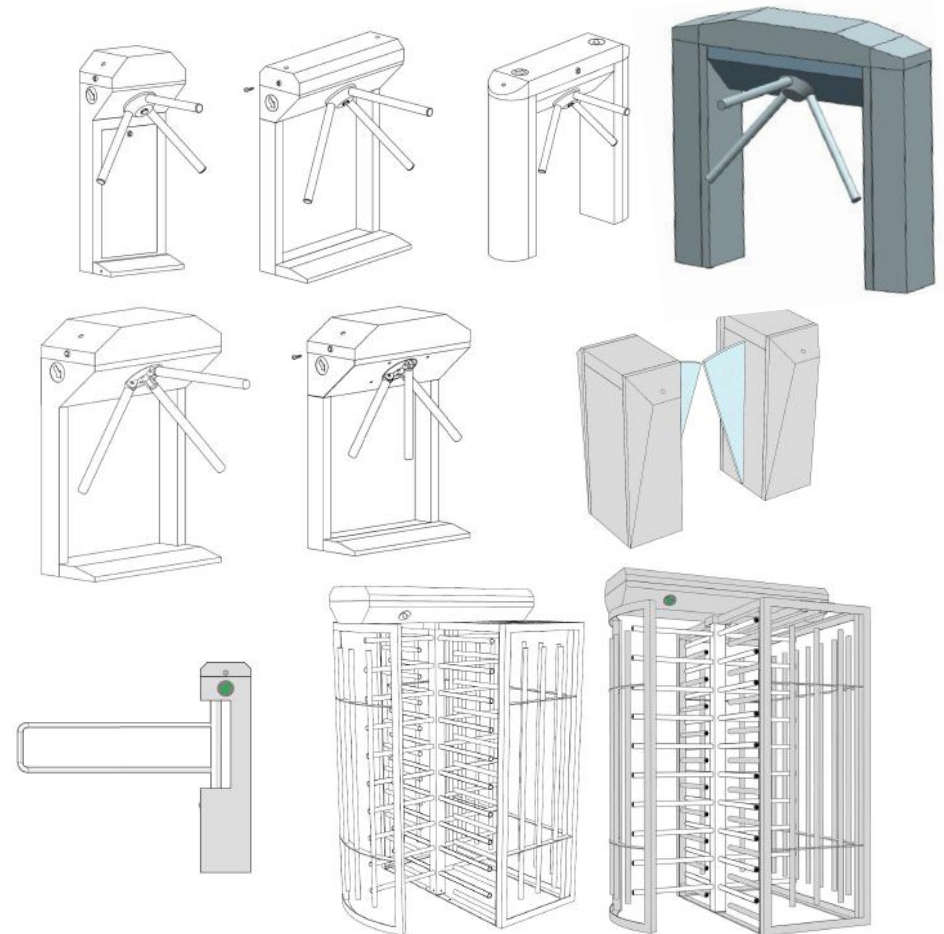



## Electro-Mechanical Tripod

### Features:

- Push type Operation, normally Locked on power , tripod arms becomes free in one direction after valid card is presented on card reader.
- Tripod arms becomes free on power failure so that free movement is possible in both directions
- Electro-Mechanical type solenoid based operation for higher reliability and ease of operation
- Tripod cabinet is available either in Powder coated steel OR stainless steel (grade 304) while tripod arms are always in 304 grade stainless steel. Arm length from 380 mm to 500 mm. default arm length is 380 mm.
- Option of choosing different type of tripod cabinets like SLIM, NEAT, CLASSIC as per application and aesthetic.
- Highly rugged design and user friendly , 3 X 120 degree Movement
- Bi-directional movement of tripods arms (clockwise and anti-clockwise) & Lane Indicator
- Highly reliable ratchet based mechanism so that tripod can be used for single card single person concept by avoiding reverse rotation of tripod arms once moved 25 degree from rest position.
- Self centering Mechanism and shock absorbers makes smooth movement of tripod arms to rest position.
- Positive action lock to prevent two rotation of tripod arms.
- Hold time is settable with reset mechanism to lock tripod arms after each 120 degree rotation
- Micro-controller based logic control module to control entire operation with SMPS power supply
- In case of emergency /fire tripod arms can become free on receipt of external signal without dis-connecting power (fail safe mode)
- Movement of tripod arms can be disabled/blocked on receipt of external signal without disconnecting power so that tripod arms movement is not possible even after valid card is presented (Fail locked mode)





## Options of Cabinet for Tripod Turnstiles

(In Powder coated steel or Stainless Steel)



SLIM Series

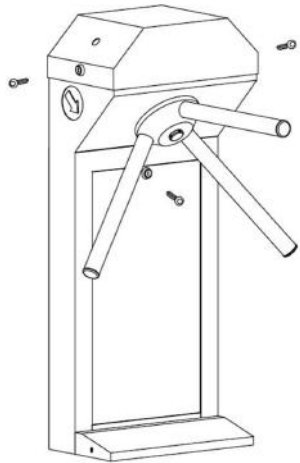

NEAT Series

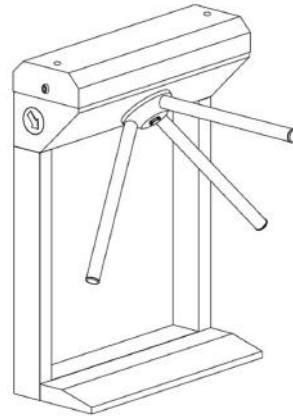

CLASSIC Series

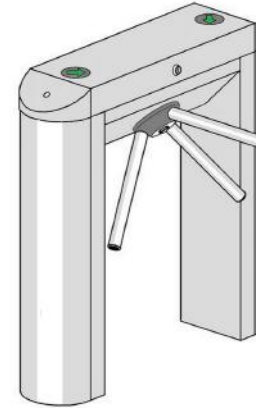



## Electro-Mechanical Drop arm Tripod

### Features:

- Push type Operation, normally Locked on power, tripod arms becomes free in one direction after valid card is presented on card reader.
- Automatic drop arm feature in case of power failure with manual reset offering clear passage for free and easy movement for pedestrian traffic and without any obstacle
- Electro-Mechanical type solenoid based operation for higher reliability and ease of operation
- Tripod cabinet is available either in Powder coated steel OR stainless steel (grade 304) while tripod arms are always in 304 grade stainless steel. Arm length from 380 mm to 500mm
- Highly rugged design and user friendly, 3 X 120 degree Movement
- Bi-directional movement of tripods arms (clockwise and anti-clockwise) & Lane Indicator
- Highly reliable ratchet based mechanism so that tripod can be used for single card single person concept by avoiding reverse rotation of tripod arms once moved 25 degree from rest position.
- Self centering Mechanism and shock absorbers makes smooth movement of tripod arms to rest position.
- Positive action lock to prevent two rotation of tripod arms.
- Hold time is settable with reset mechanism to lock tripod arms after each 120 degree rotation
- Micro-controller based logic control module to control entire operation with SMPS power supply
- In case of emergency /fire tripod arms can become free on receipt of external signal without dis-connecting power (fail safe mode)
- Movement of tripod arms can be disabled/blocked on receipt of external signal without disconnecting power so that tripod arms movement is not possible even after valid card is presented (Fail locked mode)

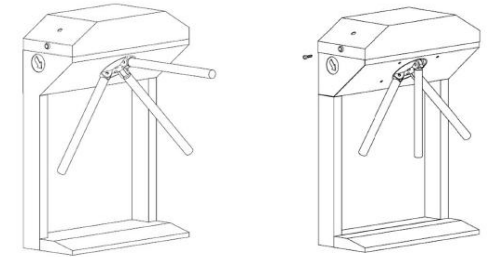



## Motorized Drop Arm Tripod

### Features:

- Motorized and hands free operation
- Automatic drop arm feature in case of power failure with auto reset offering clear passage for free and easy movement of pedestrian traffic without any obstacle
- Highly reliable DC brushless motor based drive for higher reliability and ease of operation
- Tripod cabinet is available either in Powder coated steel OR stainless steel (grade 304) while tripod arms are always in 304 grade stainless steel. Arm length from 380 mm to 500mm
- Highly rugged design and user friendly , 3 X 120 degree Movement
- Bi-directional movement of tripods arms (clockwise and anti-clockwise) & Lane Indicator
- Hold time is settable with reset mechanism to lock tripod arms after each 120 degree rotation
- Micro-controller based logic control module to control entire operation with SMPS power supply.

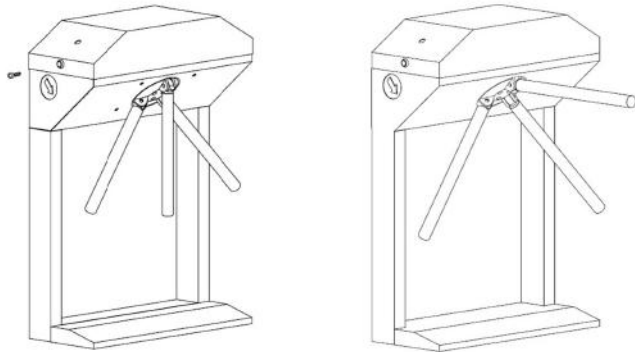



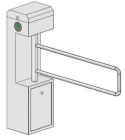

## Motorized P type Swing Gate



The PGM Series is the perfect ADA Compliant u shaped stainless steel Swing Gate for a variety of applications, from office buildings, airports, corporate headquarters, security center, wheel chairs, Museums, Public facilities , IT Parks, Sports stadium

### Features:

- Motorized and hands free operation offering comfortable & Safe passage
- Highly reliable DC brushless motor based drive for higher reliability and ease of operation
- Pgate cabinet is available either in Powder coated steel OR stainless steel (grade 304) while U shaped barrier element is always in 304 grade stainless steel.
- Elegant look . Highly rugged design and user friendly
- Bi-directional movement in both directions , 2 X 90 degree movement
- Up to 900 mm passage clearance with U-shaped made of AISI 304 tubular stainless steel.
- Rotating element locks at normal position and moves automatically in one direction after receipt of external valid signal
- Micro-controller based logic control module to control entire operation with SMPS power supply
- Ideal addition for tripod turnstiles, half-height turnstiles, Flap Barriers for handicapped lane and barrier-free access
- Simple assembly on finished floor
- Pgate can be used as wide lane for handicapped person, Wheel chairs, luggage, oversized packages , trolley movement etc

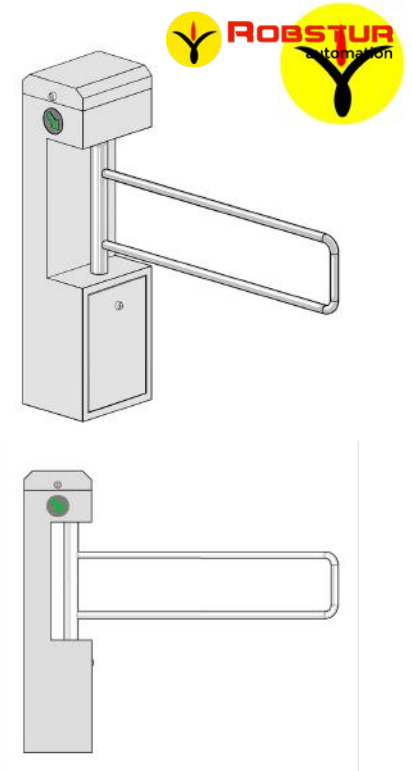

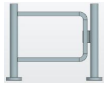

## Manual P type Swing Gate



The PGM Series is the perfect ADA Compliant u shaped stainless steel Swing Gate for a variety of applications, from office buildings, airports, corporate headquarters, security center, wheel chairs, Museums, Public facilities , IT Parks, Sports stadium

### Features:

- Electro-Magnetic based lock and hands free operation offering comfortable & Safe passage
- Highly reliable EM Lock based operation for higher reliability and ease of operation
- Pgate cabinet is available either in Powder coated steel OR stainless steel (grade 304) while barrier element is always in 304 grade stainless steel.
- Elegant look . Highly rugged design and user friendly
- 90 degree movement in either direction. Push type for one direction and pull type for other direction
- Up to 900 mm passage clearance with U-shaped made of AISI 304 tubular stainless steel.
- Manual push type operation for opening and closing is automatic
- Ideal addition for tripod turnstiles, half-height turnstiles, Flap Barriers for handicapped lane and barrier-free access
- Simple assembly on finished floor
- Pgate can be used as wide lane for handicapped person, Wheel chairs, luggage, oversized packages , trolley movement etc

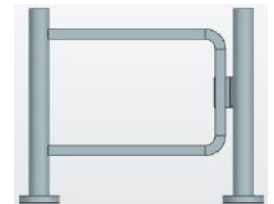



## Full Height Turnstile

Robstur full height industrial turnstiles are the ideal way to secure an area and to control the traffic that flows through it. By only letting one person at a time through the turnstile, optimum security is guaranteed. The Full-Height turnstiles is the ideal choice for maximum security for all environments owing to its human height barrier enclosures

### Features:

- Push type Operation, Normally Locked on power , Rotor becomes free in one direction after valid card is presented on card reader. Highly rugged design and user friendly
- Full height Turnstile can be configured in fail safe OR fail locked mode on power failure .
- Electro-Mechanical type solenoids (Lock and Release) based operation for higher reliability and ease of operation
- Full Height frame and top cabinet is available either in Powder coated steel OR stainless steel (grade 304) while rotor column and arms are always in 304 grade stainless steel.
- Full Height Turnstile is available in 90 X 4 way rotor for high security while 3 X 120 degree for more space.
- Bi-directional movement of tripods arms (clockwise and anti-clockwise) & Lane Indicator
- Highly reliable ratchet based mechanism so that rotor can be used for single card single person concept by avoiding reverse rotation of tripod arms once moved 25 degree from rest position.
- Self centering Mechanism and shock absorbers makes smooth movement of rotor to rest position.
- Positive action lock to prevent two rotation of tripod arms.
- Hold time is settable with reset mechanism to full height Rotor arms after each 90 degree rotation
- Micro-controller based logic control module to control entire operation with SMPS power supply
- In case of emergency /fire tripod arms can become free on receipt of external signal without dis-connecting power (fail safe mode)
- Movement of tripod arms can be disabled/blocked on receipt of external signal without disconnecting power so that tripod arms movement is not possible even after valid card is presented (Fail locked mode)

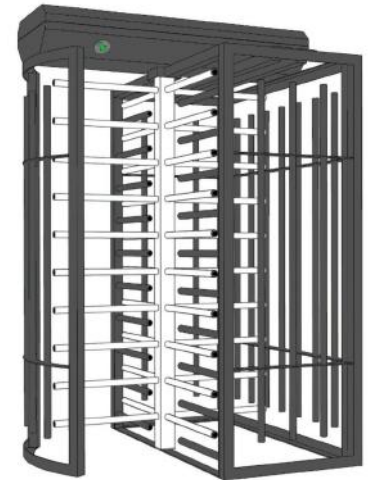

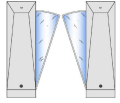

## Retractable Flap Barrier

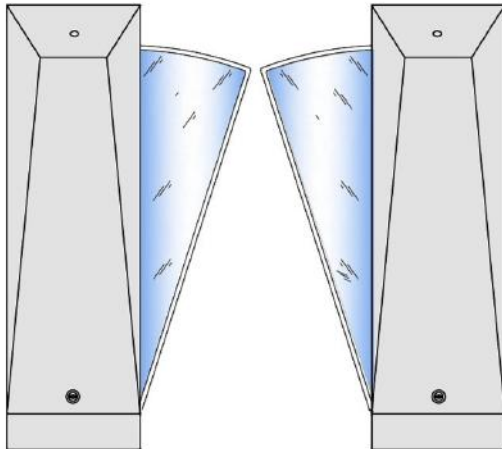

- Opening time: 1 Second
- Reset Time and hold time user settable
- Fail safe or fail lock mode in case of power failure
- Can be integrated with any third part access control

Robstur flap barrier is an innovative pedestrian control technology that designed to achieve best balance between quality, performance and affordability . Flap Barrier series provide a combination of reliable mechanical as well as electronic restriction for unauthorized visitor while still maintain a welcoming atmosphere. Access control and time attendance reader can be integrated into flap barrier to improve accuracy of reporting.

Flap barriers are available in single lane and multi lane configuration with combination of standard pedestrian and wide handicapped lane. Flap barrier is designed using DC brushless Motor and highly reliable sensors to make it safe and secure entrance solution.

### FRATURES:

- DC Brushless Motor based highly reliable drive
- IR Sensor for safety of person standing between two cabinets of flap barrier.
- Lane Indicator: Green and Red indications. Green Arrow and Red Cross.
- Cabinet: Mild Steel Powder coated OR Stainless Steel grade 304 (optional 316 )
- Flap/Wings: Acrylic , transparent
- Cabinet Width: 300 MM and Height: 1000 MM for standard lane
- Power : 230 VAC @ single Phase , 50 Hz,
- Passage width: 520 mm for pedestrian and 900 for wide lane used for handicapped lane
- Optional crawling sensor , Counter , tailgate detection feature , customized reader mounting proviison